



Figure 1a

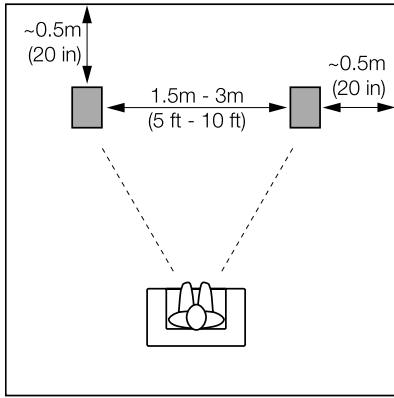

Figure 1b

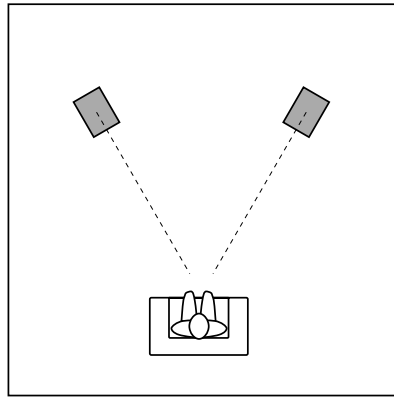

Figure 1c 5.1 Channels

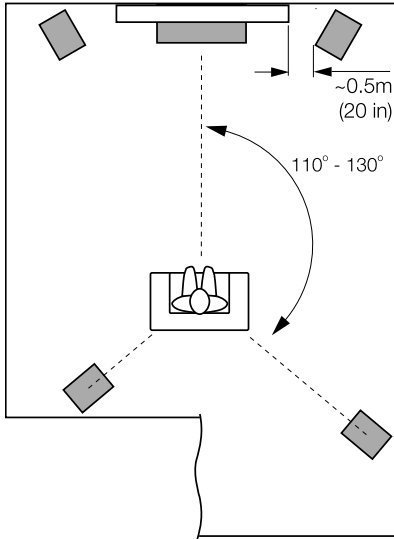

Figure 1d 6.1 Channels

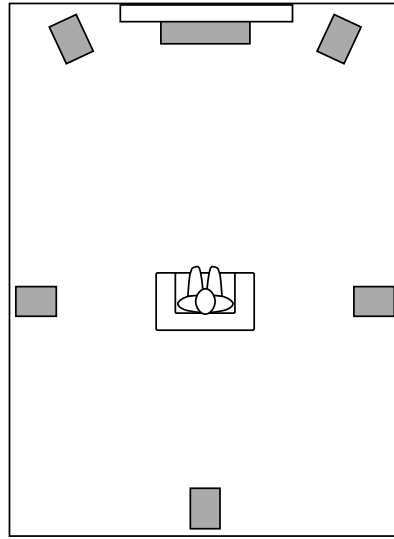

Figure 1e 7.1 Channels

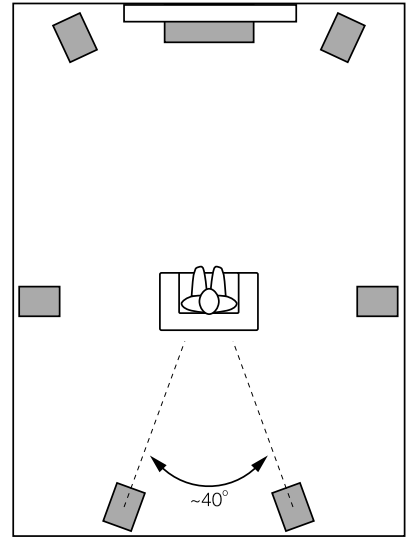

Figure 2

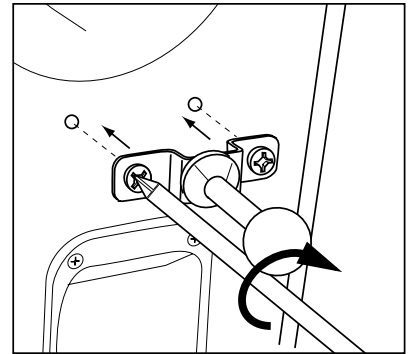
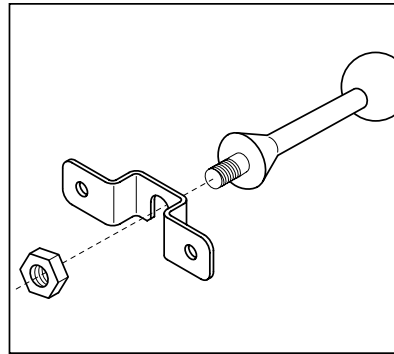
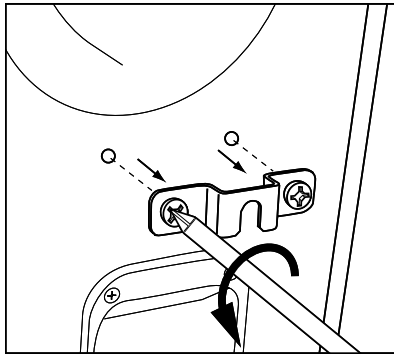

Figure 2b

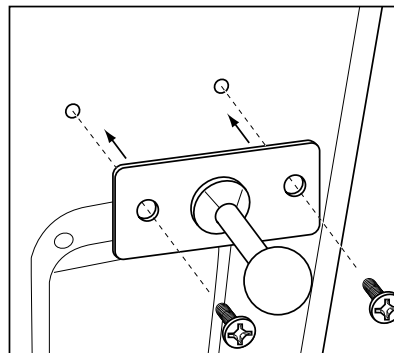
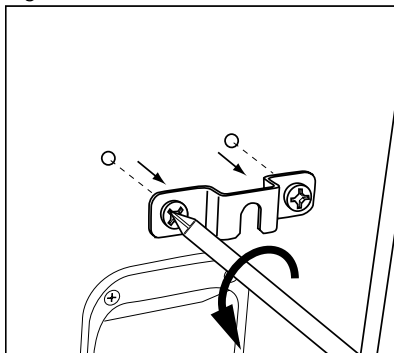

Figure 3a

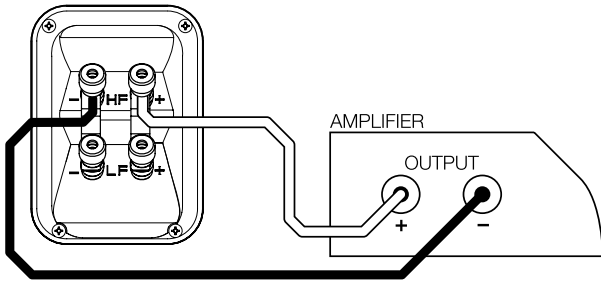

Figure 3b

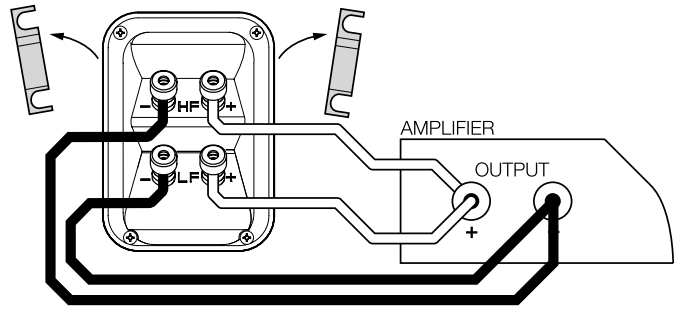
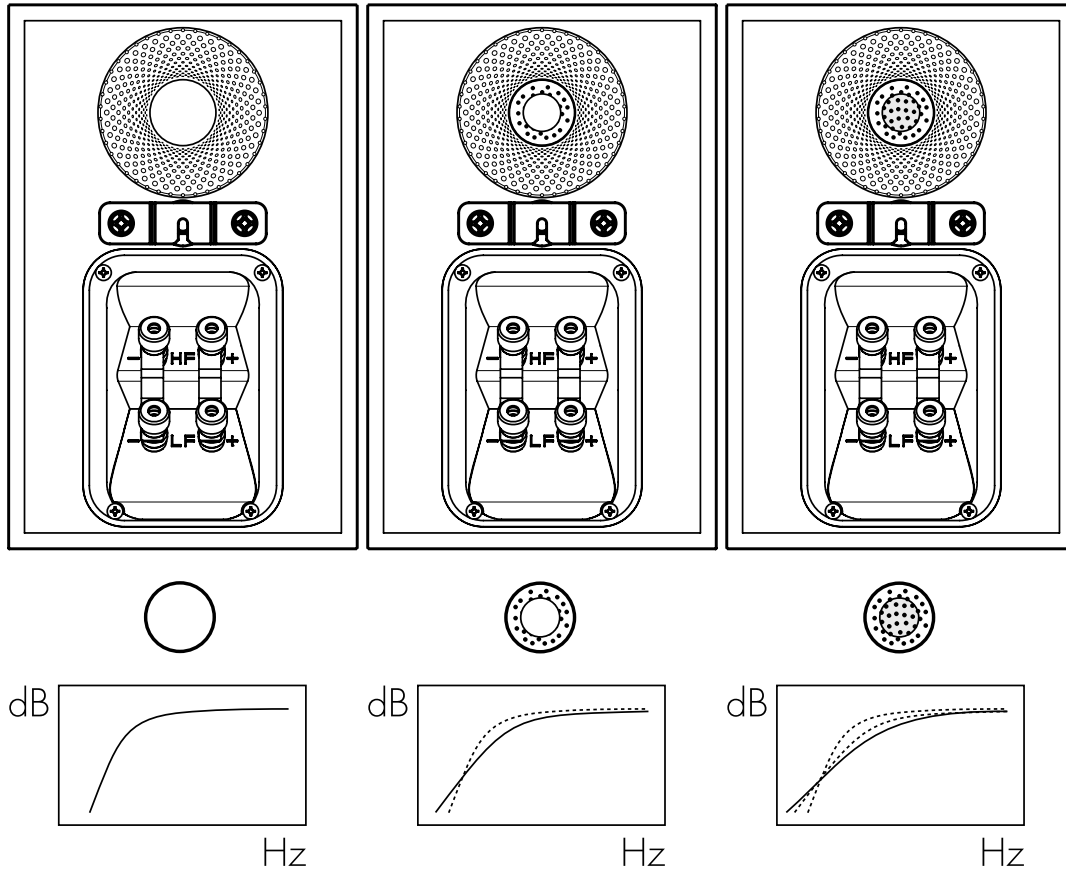

Figure 4



English

Owner's manual

Dear customer,

Thank you for choosing B&W. Please read this manual fully before unpacking and installing the product. It will help you to optimise its performance. B&W maintains a network of dedicated distributors in over 60 countries who will be able to help you should you have any problems your dealer cannot resolve.

Environmental Information



B&W products are designed to comply with international directives on the Restriction of Hazardous Substances (RoHS) in electrical and electronic equipment and the disposal of Waste Electrical and Electronic Equipment (WEEE). The crossed wheellie bin symbol indicates compliance and that the products must be appropriately recycled or processed in accordance with these directives.

Carton Contents

Check in the carton for:

- 2 Foam plugs
- 8 Self-adhesive rubber pads
- 4 Self-adhesive rubber stand-offs

Speaker Installation

The speakers are best used mounted on rigid floor-stands that locate the tweeters approximately at ear level when seated. Shelf or wall bracket mounting is an option but it provides less opportunity for optimising the sound through adjustment of speaker position.

If the speakers are to be stood on a shelf or furniture unit the adhesive pads supplied may be used.

The speakers can be mounted on walls using either the "keyhole" aperture hardware already attached to their back panels or by employing ball-joint style speaker mounting brackets designed for 60mm (2.36 in) mounting hole centres. If the keyhole hardware is employed, the rubber pads supplied in the accessory pack may be used to cushion the speakers against the wall. Ball-joint style brackets allow the speakers to be angled with respect to the wall. You should ensure that the ball-joint brackets are capable of supporting the weight of the speaker. Your dealer or local B&W distributor will be able to advise you on the selection of appropriate ball-joint brackets.

To attach a ball-joint style bracket to a 686 speaker, remove the bracket hardware from the back panel of the speaker and securely attach it via the keyhole aperture to the ball component of the bracket. Re-attach the bracket and ball assembly to the back panel. Figure 2a illustrates this procedure.

To attach a ball-joint style bracket to a 685 speaker, remove the bracket hardware from the back panel of the speaker and securely attach the ball joint plate component in its place. Figure 2b illustrates this procedure.

Once the ball joint component is attached to the speaker, the assembly may be connected to the socket component attached to the wall. Ensure that the Manufacturer's instructions for attaching the bracket to the wall are followed correctly.

If either keyhole or ball-joint style solutions are used, ensure that the wall fixings are sufficient to hold the weight of the speakers. B&W can accept no liability for any failure of wall fixings.

Speaker Positioning

Adjustment of speaker position following initial installation will probably further improve the sound quality and is usually worthwhile.

In either stereo or home theatre installations try to ensure that the immediate surroundings of each speaker are similar in acoustic character. For example, if one speaker is adjacent to bare walls while the other is adjacent to soft furnishings and curtains, both the overall sound quality and the stereo image are likely to be compromised.

Conventional Stereo Systems

To begin with, the speakers should be positioned between 1.5m (5 ft) and 3m (10 ft) apart at two corners of an equilateral triangle completed by the listening area at the third corner. The speakers should be approximately 0.5m (20 in) away from the back wall, and at least 0.5m (20 in) away from any side walls. Figure 1a illustrates this arrangement.

Home Theatre Systems

If the speakers are to be used for the front channels in a home theatre system they should be placed closer together than for 2-channel audio because the surround channels tend to widen the image. Positioning the speakers within approximately 0.5m (20 in) of the sides of the screen will also help keep the sound image in scale with the visual image. The speakers' height should be somewhere between the centre of the screen and the height of the centre speaker. As with conventional stereo positioning, the speakers should ideally be approximately 0.5m (20 in) away from the back wall, and at least 0.5m (20 in) away from any side walls.

If the speakers are to be used for the surround channels in a home theatre system position them as illustrated in Figures 1c to 1e according to the number of channels. To achieve even coverage over an extended listening area it is beneficial to raise the speakers above ear height.

Stray Magnetic Fields

The speaker drive units create stray magnetic fields that extend beyond the boundaries of the cabinet. We recommend you keep magnetically sensitive articles (CRT television and computer screens, computer discs, audio and video tapes, swipe cards and the like) at least 0.5m (20 in) from the speaker. LCD and plasma screens are not affected by magnetic fields.

Connections

All connections should be made with the equipment switched off.

There are 2 linked pairs of terminals on the back of the speaker. For conventional connection the terminal links should remain in place (as delivered) and just one pair of terminals connected to the amplifier. For bi-wire connection the terminal links should be removed and each pair of terminals connected to the amplifier independently. Bi-wiring can improve the resolution of low-frequency detail. Figures 3a and 3b illustrate conventional and bi-wire connection.

Ensure that positive terminals on the speaker (marked + and coloured red) are connected to the positive output terminal on the amplifier and that negative terminals on the speaker (marked – and coloured black) are connected to the negative output terminal on the amplifier. Incorrect connection can result in poor imaging and loss of bass.

Ask your dealer for advice when selecting speaker cable. Keep its total impedance below the maximum recommended in the speaker specification and use a low inductance cable to avoid attenuation of high frequencies.

Fine Tuning

Before fine tuning, make sure that all the connections in the installation are correct and secure.

Moving the speakers further from the walls will generally reduce the volume of bass. Space behind the speakers will also help to create an aural impression of depth. Conversely, moving the speakers closer to the walls will increase the volume of bass. If you want to reduce the volume of bass without moving the speakers further from the wall, fit the foam plugs in the port tubes as illustrated in Figure 4.

If the bass seems uneven with frequency this will most probably be due to resonance modes in the listening room. Even small changes in the position of the speakers or the listening position can have a profound effect on how these resonances affect the sound. Try moving the listening position or locating the speakers along a different wall. The presence and position of large pieces of furniture can also influence resonance modes.

If the central image lacks focus, try moving the speakers closer together or angling them inward so that they point at a location just in front of the listening position. Figure 1b illustrates speakers angled inwards.

If the sound is too bright, increasing the amount of soft furnishing in the room (heavier curtains for example) may help balance the sound. Conversely, reducing the amount of soft furnishing may help brighten a dull sound.

Some rooms suffer from "flutter echoes" – echoes that "bounce" between parallel room boundaries. Flutter echoes can colour the sound of the speakers in the room. Test for flutter echoes by standing in the middle of the room and clapping your hands. Flutter echoes can be reduced by placing irregular shaped items or

non-reflective surfaces, bookshelves, rugs or pictures for example, on one of the offending walls or floor.

Ensure that the speaker stands are upright and firm on the floor. Use carpet piercing spikes if appropriate and adjust them to take up any unevenness.

Running-in Period

The performance of the speaker will change subtly during the initial listening period. If the speaker has been stored in a cold environment, the damping compounds and suspension materials of the drive units will take some time to recover their correct mechanical properties. The drive unit suspensions will also loosen up during the first hours of use. The time taken for the speaker to achieve its intended performance will vary depending on previous storage conditions and how it is used. As a guide, allow up to a week for the temperature effects to stabilise and 15 hours of average use for the mechanical parts to attain their intended design characteristics.

However, longer run-in periods (as long as a month) have been reported and there is evidence to suggest that this has little to do with the speaker changing and more to do with the listener getting used to the new sound. This is especially so with highly revealing speakers such as these where there may be a significant increase in the amount of detail compared with what the listener has previously been used to; the sound may at first appear too "up front" and perhaps a little hard. After an extended period of time the sound will seem to mellow, but without losing clarity and detail.

Aftercare

The cabinet surfaces usually only require dusting. If you wish to use an aerosol or other cleaner, remove the grille first by gently pulling it away from the cabinet. Spray aerosols onto the cleaning cloth, not directly onto the product. Test a small area first, as some cleaning products may damage some of the surfaces. Avoid products that are abrasive, or contain acid, alkali or anti-bacterial agents. Do not use cleaning agents on the drive units. The grille fabric may be cleaned with a normal clothes brush whilst the grille is detached from the cabinet. Avoid touching the drive units, especially the tweeter, as damage may result.

Limited Warranty

This product has been designed and manufactured to the highest quality standards. However, if something does go wrong with this product, B&W Group Ltd. and its national distributors warrant free of charge labour (exclusion may apply) and replacement parts in any country served by an official B&W distributor.

This limited warranty is valid for a period of five years from the date of purchase or two years for electronics including amplified loudspeakers.

Terms and Conditions

- 1 The warranty is limited to the repair of the equipment. Neither transportation, nor any other costs, nor any risk for removal, transportation and installation of products is covered by this warranty.
- 2 This warranty is only valid for the original owner. It is not transferable.
- 3 This warranty will not be applicable in cases other than defects in materials and/or workmanship at the time of purchase and will not be applicable:
 - a. for damages caused by incorrect installation, connection or packing,
 - b. for damages caused by any use other than correct use described in the user manual, negligence, modifications, or use of parts that are not made or authorised by B&W,
 - c. for damages caused by faulty or unsuitable ancillary equipment,
 - d. for damages caused by accidents, lightning, water, fire heat, war, public disturbances or any other cause beyond the reasonable control of B&W and its appointed distributors,
 - e. for products whose serial number has been altered, deleted, removed or made illegible,
 - f. if repairs or modifications have been executed by an unauthorised person.
- 4 This guarantee complements any national/regional law obligations of dealers or national distributors and does not affect your statutory rights as a customer.

How to claim repairs under warranty

Should service be required, please follow the following procedure:

- 1 If the equipment is being used in the country of purchase, you should contact the B&W authorised dealer from whom the equipment was purchased.
- 2 If the equipment is being used outside the country of purchase, you should contact the B&W national distributor in the country of residence who will advise where the equipment can be serviced. You can call B&W in the UK or visit our web site to get the contact details of your local distributor.

To validate your warranty, you will need to produce the warranty booklet completed and stamped by your dealer on the date of purchase. Alternatively, you will need the original sales invoice or other proof of ownership and date of purchase.

Français

Manuel d'utilisation

Cher Client,

Nous vous remercions d'avoir choisi B&W. Veuillez lire soigneusement ce manuel avant de débiller et d'installer vos enceintes acoustiques. Il vous aidera à en obtenir les performances optimales. B&W est distribué dans plus de 60 pays dans le monde entier, par l'intermédiaire de distributeurs spécialement sélectionnés ; ceux-ci pourront vous aider à résoudre d'éventuels problèmes ignorés par votre revendeur.

Information sur la protection de l'environnement



Les produits B&W sont conçus en conformité totale avec les nouvelles normes internationales concernant l'interdiction d'utilisation de certaines substances dangereuses (RoHS) dans les équipements électriques et électroniques, ainsi que la possibilité de recyclage des matériaux utilisés (WEEE, pour Waste Electrical and Electronic Equipment). Le symbole du conteneur à ordures barré par une croix indique la compatibilité avec ces directives, et le fait que les appareils peuvent être correctement recyclés ou traités dans le respect total de ces normes.

Vérification du contenu de l'emballage

Vérifiez que le carton contienne bien :

- 2 tampons en mousse
- 8 pieds en caoutchouc auto-adhésifs
- 4 entretoises en caoutchouc auto-adhésives

Installation des enceintes

Les enceintes seront de préférence montées sur des pieds de sol rigides, positionnant les tweeters approximativement à la hauteur des oreilles des auditeurs assis. L'installation sur des étagères ou via des supports muraux est une option, qui ne permettra toutefois pas autant de souplesse quant à l'optimisation des résultats sonores en fonction de la position réelle des enceintes.

Si les enceintes doivent être posées sur une étagère ou un meuble, utilisez les pieds en caoutchouc auto-adhésifs fournis.

Les enceintes peuvent être fixées au mur en utilisant simplement le trou de fixation type « trou de serrure » visible sur leur face arrière, ou par l'intermédiaire de supports de montage spécifiques orientables, conçus spécifiquement pour des trous de fixation de 60 mm. Si la fixation « trou de serrure » est utilisée, les tampons de caoutchouc fournis dans le kit d'accessoires pourront être utilisés, dans la zone de contact entre l'enceinte et le mur. Les supports orientables permettent d'orienter précisément chaque enceinte quelle que soit la position du mur. Assurez-vous que les supports choisis sont capables de supporter le poids de l'enceinte. Votre revendeur agréé B&W vous donnera toutes les informations utiles sur le choix d'un tel support réellement adapté.

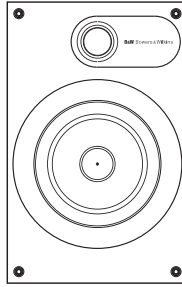

686

Technical features	Nautilus™ tube-loaded aluminium dome tweeter Kevlar® brand fibre cone bass/midrange Flowport™
Description	2-way vented-box system
Drive units	1x ø25mm (1 in) aluminium dome high-frequency 1x ø130mm (5 in) woven Kevlar® cone bass/midrange
Frequency range	-6dB at 45Hz and 50kHz
Frequency response	55Hz - 22kHz ±3dB on reference axis
Dispersion	Within 2dB of reference response Horizontal: over 60° arc Vertical: over 10° arc
Sensitivity	84dB spl (2.83V, 1m)
Harmonic distortion	2nd and 3rd harmonics (90dB, 1m) <1% 110Hz - 22kHz <0.5% 150Hz - 20kHz
Nominal impedance	8Ω (minimum 5.1Ω)
Crossover frequency	4kHz
Recommended amplifier power	30W - 100W into 8Ω on unclipped programme
Max. recommended cable impedance	0.1Ω
Dimensions	Height: 265mm (10.5 in) (not including feet) Width: 170mm (6.7 in) Depth: 284mm (11.2 in) (including grille and terminals)
Net weight	4.9kg (10.8 lb)

B&W Bowers & Wilkins

B&W Group Ltd
Dale Road
Worthing West Sussex
BN11 2BH England

T +44 (0) 1903 221800
F +44 (0) 1903 221801
info@bwgroup.com
www.bowers-wilkins.com

B&W Group (UK Sales)
T +44 1903 221 500
E uksales@bwgroup.com

B&W Group North America
T +1 978 664 2870
E marketing@bwgroupusa.com

B&W Group Asia Ltd
T +852 2 869 9916
E info@bwgroup.hk

Kevlar is a registered trademark of DuPont.
Nautilus is a trademark of B&W Group Ltd.
Copyright © B&W Group Ltd. E&OE
Printed in China.